

## Tools Required

- 4 ft. level
- Hammer
- Hammer drill
- Misc. screwdriver bits
- Hacksaw
- Misc. drill bits, including 4mm (5/32") & 8mm (5/16")
- 6mm (1/4") masonry bit
- 11mm (7/16") wrench
- 13mm (1/2") wrench
- 17mm (11/16") open end wrench
- Chalkline
- 318mm (12.5") shim block
- 6-lobe driver bit for upper hinge pin
- Tape measure

# M E T A L

## CEILING HUNG INSTALLATION MANUAL



## General Notes

The following installation instructions are based on the most common unit arrangement. Other arrangements will be encountered, i.e. units contained between two walls or between two freestanding panels.

For dimensional information, refer to your plan layout and dimensional details. Note in particular the relationship of the panels to the pilasters (panels do not necessarily fall on the centerline of the pilaster).

Ceiling hung toilet partitions require an overhead structural member (normally a channel). This member is supplied, installed, and drilled by others.

Hadrian supplies the stud assemblies but does not install them. Stud assemblies should be in place prior to application of finished ceiling.

Varying site conditions can affect the installation process. To effect a rigid and level installation, it is important for installers to be aware of and compensate for uneven floor and wall conditions.

It is the distributor's responsibility to supply end-users with maintenance and warranty information.

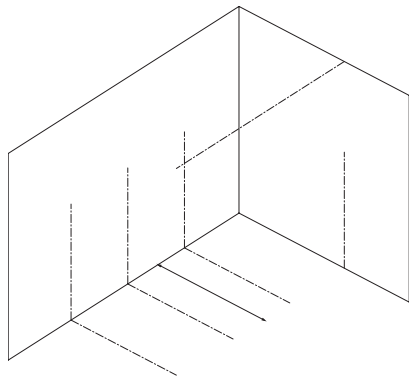

**1**

### Establish Ceiling Stud Locations

Establish front centerline by taking the overall compartment dimension and deducting 16 mm (5/8").

Use final layout drawings to determine locations.

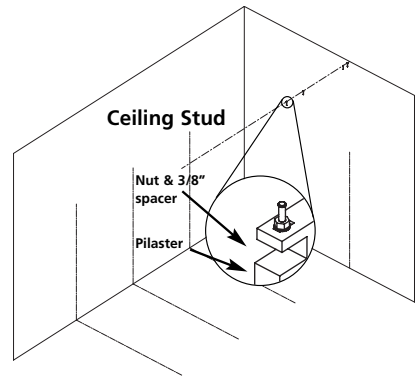

**2**

### Fasten Ceiling Studs

Drill holes for ceiling studs 25mm (1") in from edge of pilaster locations as indicated on layout drawing.

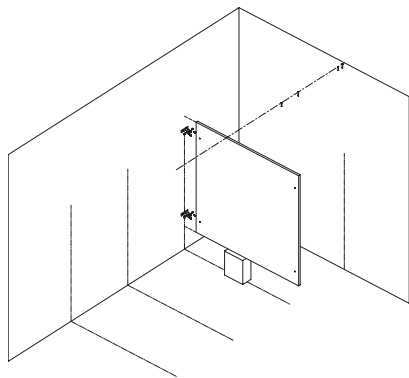

**3**

### Erect Panel

Using your centerline locations, fasten 2 panel brackets to wall. Bracket centers should be 457mm (18") and 1626mm (64") from floor.

Rest panel on 318mm (12.5") block and position in brackets, leaving 13mm (1/2") clearance between wall and panel. Drill one hole through top bracket and fasten.

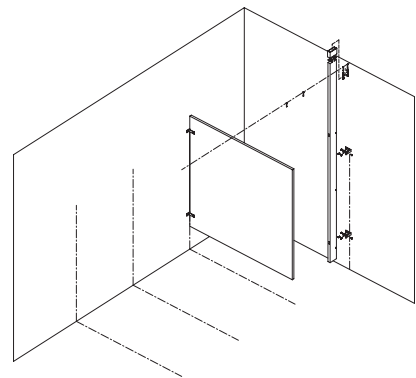

**4**

### Erect Wall Pilaster

Fasten 2 "F" brackets to wall at centerline. Bracket centers should be 457mm (18") and 1626mm (64") from floor.

Slide shoe onto pilaster. Position pilaster in wall brackets and over ceiling studs. Install ceiling stud hardware, plumb pilaster, and tighten. Attach pilaster to wall brackets.

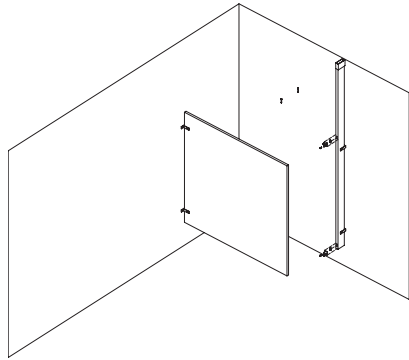

**5**

#### Prepare Pilaster For Door

Fasten upper and lower hinges to wall pilaster.

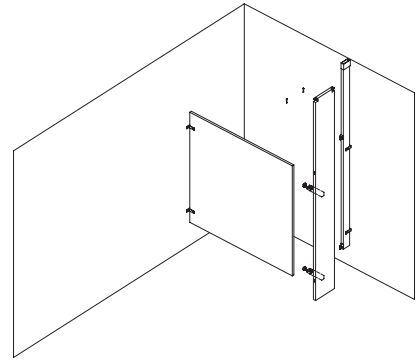

**6**

#### Fasten "U" Brackets To Pilaster

Place next pilaster on ceiling studs and mark center line of panel on the back. Mark bracket centers at 457mm (18") and 1626mm (64") from floor. Using the brackets as templates, mark drill holes.

Remove pilaster from ceiling studs and fasten "U" brackets.

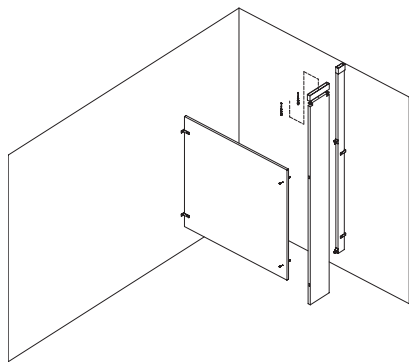

**7**

#### Erect Pilaster

Slide shoe onto pilaster and position pilaster on ceiling studs with "U" brackets engaging panel. Install ceiling stud hardware, plumb pilaster, and tighten.

Drill hole through top bracket and fasten.

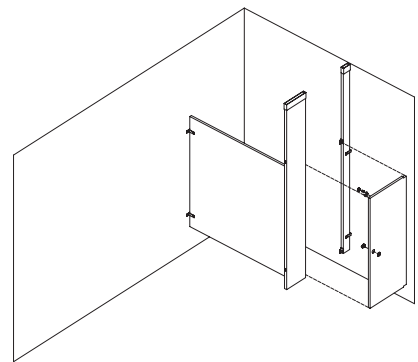

**8**

#### Prepare Door For Hanging

Install female cam in the door.

Install latch, and coat hook/bumper.

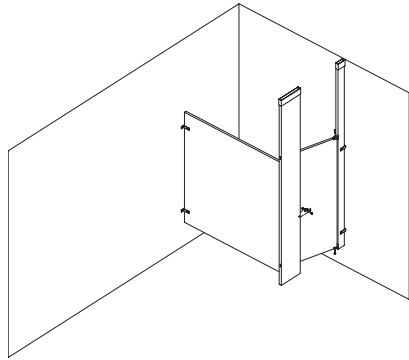

## 9

### Hang Door

Insert male cam into bottom hinge and lower door onto it. Install threaded upper hinge pin. To set doors at the required angle, loosen the nut of the male cam assembly, set door at required angle, and tighten nut.

Fasten Stop & Keeper on pilaster, ensuring it lines up with latch.

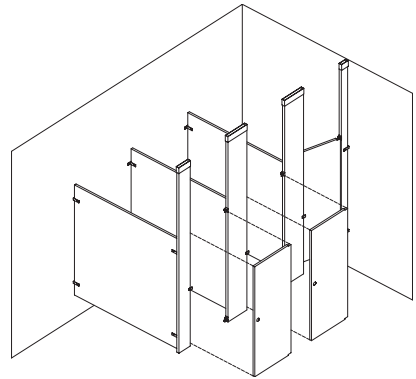

## 10

### Erect Remaining Compartments

Ensure all pilasters are fastened to ceiling studs, add all remaining fasteners and repeat steps 3-10 (as necessary) for all remaining compartments.

Note: Hadrian recommends installing one compartment (including door) at a time.

## Optional Items

### Continuous Hinge

Replaces conventional hinge and hinge filler.

### Continuous Stop

Replaces doorstop/keeper and offers increased privacy.

### Hinge Side Gap Filler

Fits between standard hinges and offers increased privacy.

Hadrian recommends pre-drilling pilasters with 4mm (5/32") holes when installing continuous stops and hinge side gap fillers.

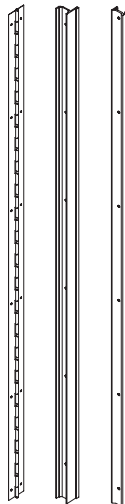

## Contact Hadrian:

**IN CANADA &  
AREAS OTHER THAN USA:**  
Hadrian Manufacturing Inc.,  
965 Syscon Road,  
Burlington, ON L7L 5S3  
tel: 905-333-0300  
fax: 905-333-1841  
CAN toll free fax: 1-888-817-7701

**IN THE USA:**  
Hadrian Inc.,  
7420 Clover Ave.,  
Mentor, OH 44060  
tel: 440-942-9118  
fax: 440-942-9618  
USA toll free fax: 1-800-536-1469